

FEATURES

- Miniature open frame package
- Epoxy coated
- Moisture resistant
- Spectral response similar to the human eye
- Applications include dusk-dawn lighting control

LIGHT DEPENDENT RESISTOR

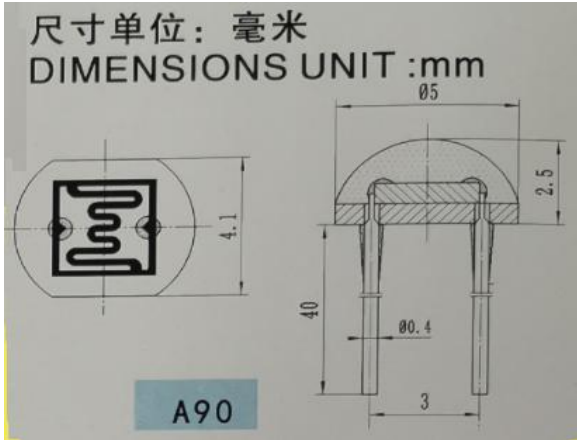

Dimensions in millimetres

SPECIFICATION AND PERFORMANCE

Model	Vmax (VDC)	Pmax (mW)	Ambient temp(°C)	Spectral peak (nm)	Light Resistance at 10Lux (KΩ)	Dark Resistance (MΩ)	Gamma value at 100-10Lux	Response Time (ms)	
								Rise Time	Decay time
A906009	100	90	-30~+70	600	4-11	0.12	0.65	30	30
A906011	150	90	-30~+70	600	9-20	0.18	0.65	30	30
A906012	150	90	-30~+70	600	16-33	0.5	0.7	30	30
A906013	150	90	-30~+70	600	27-94	1.5	0.8	30	30
A906014	150	90	-30~+70	600	77-340	5	0.85	30	30

测试条件

- 1.亮电阻：用400-600Lux光照射60-90分钟后，在标准光源A(色温2854K)下，用10Lux光测量。
- 2.暗电阻：关闭10Lux光照后第10秒的电阻值（特别注明除外）。
- 3.γ：是指10Lux和100Lux照度下的标准值。

$$\gamma = \frac{\lg(R_{10}/R_{100})}{\lg(100/10)} = \lg(R_{10}/R_{100})$$

R10、R100分别为10Lux和100Lux照度下的电阻值。

γ的公差为±0.15。

4.最大功率损耗：环境温度25℃时的最大功率。

5.最大外加电压：在黑暗中可连续施加给元件的最大电压。

焊接条件

- 1.焊接温度：小于260℃
- 2.焊接时间：不大于3秒
- 3.焊接距离（距离基板底部）：大于3mm

注：

- 1.本规格书所列型号为常规型号，可根据客户需求特别定制。
- 2.请在规格要求范围内使用，严禁超负荷使用。

Measuring Conditions

1. Light resistance: Measured at 10 Lux with standard light A (2854K color temperature) and 60-90minutes illumination at 400-600 Lux prior testing.

2. Dark Resistance: Measured 10 seconds after closed 10 lux (The special notes are not included) .

3. Gamma Characteristic: Between 10 lux and 100 lux and given by

$$\gamma = \frac{\lg(R_{10}/R_{100})}{\lg(100/10)} = \lg(R_{10}/R_{100})$$

R10、R100 Cell resistance at 10 lux and 100 lux.

The error of γ is ±0.15

4. P max: Max. Power dissipation at ambient temperature of 25 °C.

5. V max: Max. Voltage in darkness that may be applied to the cell continuously.

Soldering condition requirements:

1. temperature: less than 260
2. Time: equal or less than 3 seconds
3. Distance from case: more than 3mm

Notes :

1. Here listed types are common ones and customized selections available on request.

2. Please use it within the specifications requirements. No overload is allowed.

Tel:+86-755-23210829 Fax:+86-755-23210825

E-mail:mk0622@163.com.