



深圳市晶创和立科技有限公司

DEVICE SPECIFICATION FOR PYRO-ELECTRIC IR-DETECTOR

Customer :
Type : PYQ 5868
Part no. : 3774
No. of samples:

Quad detector (two pairs element detectors above each other) serial opposed format, with reversed polarity ceramic material. The signal is converted to a digital value. Additionally temperature information will be provided by the detector.

This specification is provided by

Excelitas Technologies GmbH & Co. KG, Wiesbaden.

It covers the complete technical data of a pyro-electric IR detector. In case of samples attached to this paper, these have been taken randomly from normal production output. All detectors have met the requirements of Excelitas test-specifications and passed outgoing inspection.

We kindly ask for approval with the return of a signed copy.

Checked:

Date: 01.03.2013

Customer approval:

Date:

Electrical Configuration:

The pyro-electric sensing elements are connected to a built-in IC, whose detailed description follows:

The ADC contains an on-chip low-power oscillator, an analogue-to-digital converter which generates a digital signal from the voltage level of the sensing elements, a digitalised temperature dependent voltage and a serial interface, which outputs the digital signal as a bitstream to DIRECT LINK. The ADC block diagram and the data transmission are shown below.

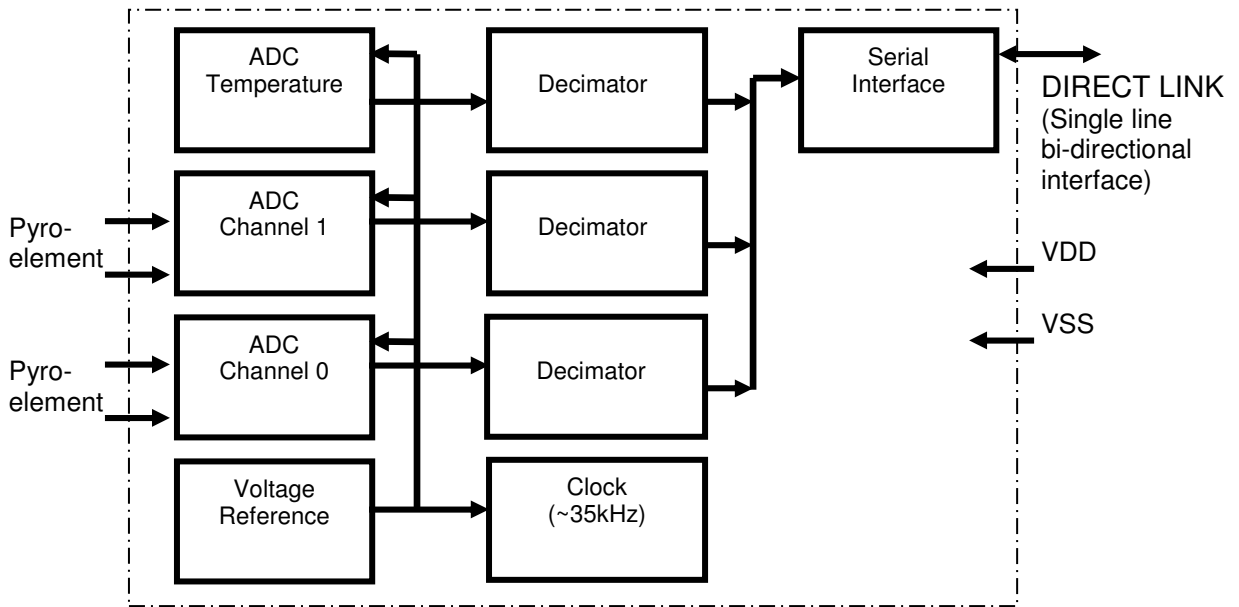

Fig. 1: Block Diagram

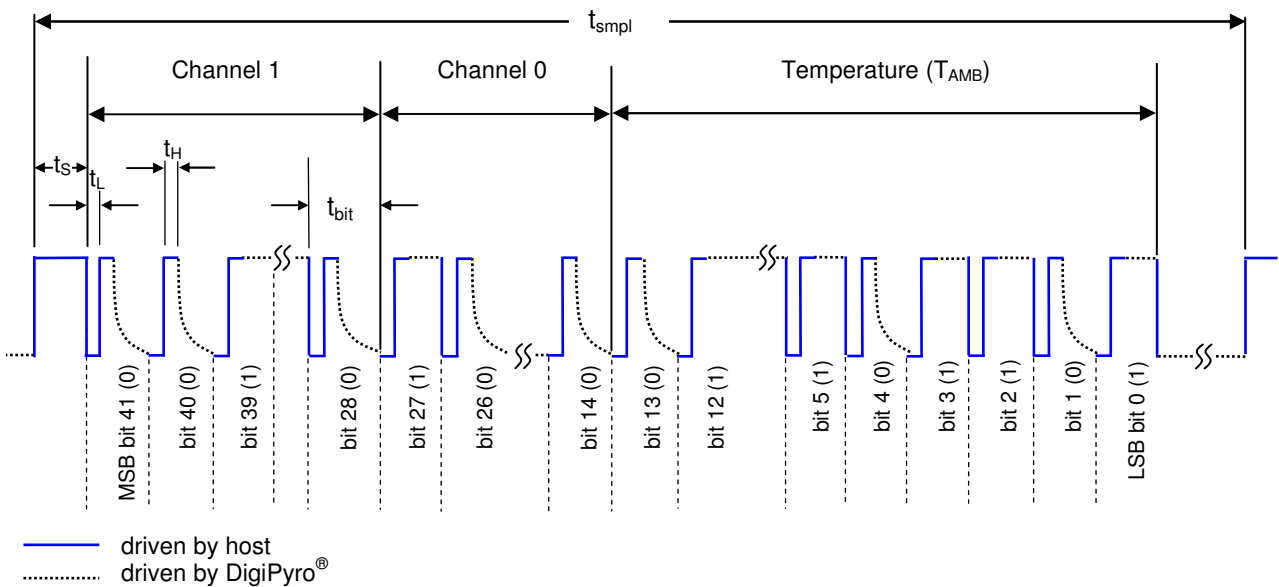

Fig. 2: Data Transmission Diagram



深圳市晶创和立科技有限公司

The serial interface has a 3 x 14 bit binary output format (Channel 1, Channel 0, Temperature) which allows a physical data value range from 0 ... 16383 for each channel. The DIRECT LINK pin is bi-directional data output and clock input.

The ADC converts signal samples continuously every 32 f_{CLK} cycles. New data is passed to the output latch of the serial interface if DIRECT LINK is LOW and not busy by a read operation.

Read Out Procedure:

Forcing DIRECT LINK to HIGH for at least 3 f_{CLK} cycles (t_s) will start the transmission from the DigiPyro[®]. After this setup time (t_s) has passed the DigiPyro[®] expects a LOW to HIGH transition (t_L, t_H) on the DIRECT LINK pin and will subsequently output the data bit state. When a bit has been read, the DigiPyro[®] waits for the next LOW to HIGH transition and the sequence will be repeated until all 42 bits are shifted out. After the last t_{bit} of bit[0] the host controller must force DIRECT LINK pin to LOW and subsequently release DIRECT LINK (High Z).

The time that the signal needs to settle to a LOW level depends on the capacitive load (e.g. PCB design) at the DIRECT LINK pin. Hence, it is recommended to start implementing the interface with t_{bit} close to but shorter than 25 μ s to ensure proper LOW level settling. In next steps reduce t_{bit} empirically to optimize for reliable data transmission at maximum transmission speed.

It has to be considered that t_{bit} must not exceed $1/f_{CLK}$ (25 μ s) to avoid data corruption. (Under no circumstances DIRECT LINK may be at LOW level for longer than 25 μ s). Also, the total time to readout one data packet may not exceed 32 clock cycles (~800 μ s).

In order to reduce settling effects, the data packets have to be read continuously with equal sampling intervals.

It is allowed to cancel the readout of a data packet after a certain number of bits have been read.

For example: reading only from bit[41] to bit[14], skips reading the temperature channel. After bit[14] has been read, DIRECT LINK must be held at LOW level and subsequently released (High Z).

Note: DL will be pulled HIGH every 512 clock cycles. The next data packet has to be read before this HIGH signal occurs.

To avoid saturation of the detector, the DigiPyro[®] contains an out of range detection logic. The input of the ADC is shorted for a time of 512 system clocks when the digital values are above 15872 counts or below 511 counts.



深圳市晶创和立科技有限公司

Electrical Data:

Unless specified differently all data refers to 25 °C.

Tab. 1: Electrical data of ADC

Parameter	Symbol	Min.	Typ.	Max.	Unit	Remarks
Operating Voltage	VDD	2.7	3.3	3.6	V	
Supply Current	IDD			15	μA	VDD = 3.3V
Input Low Voltage	V _{IL}			0.2V _{DD}	V	
Input High Voltage	V _{IH}	0.8V _{DD}			V	
Pull up Current			130		μA	Input to V _{SS}
Pull down Current			200		μA	Input to V _{DD}
Data Setup Time	t _s	100		150	μs	
Data Clock Low Time	t _L	200		2000	ns	t _{bit} < 1/ f _{CLK}
Data Clock High Time	t _H	200		2000	ns	
Sample Time	t _{smp}	2.0		13.8	ms	(3 ... 512) / f _{CLK}
Direct Link Bit Time	t _{bit}			25	μs	To avoid data corruption
ADC Counts of Bits			42		Bits	
ADC Resolution			14		Bits	Max Count = 2 ¹⁴ -1
ADC Sensitivity		6.0	6.5	7.1	μV/Count	
ADC Temperature Coefficient		-300		300	ppm/K	
ADC Output Offset		7000	8192	9200	Counts	
Sensitivity of T _{AMB}		72	80	88	Counts/K	-20 °C to + 90 °C
Linearity of T _{AMB}		-5		5	%	-20 °C to + 90 °C
Counts at Ambient Temperature		5700	6700	7700	Counts	@ 25 °C
Internal Clock Frequency	f _{CLK}	30.2	35.0	39.8	kHz	- 20 °C to + 80 °C
Temperature Coefficient	T _C (f _{CLK})	-1000		+1000	ppm/K	- 20 °C to + 80 °C

The typical offset is 8192 counts, which is comparable to a DC voltage of ~53.3mV. The output signals can be in the range of 511 counts (3.32mV) to 15872 counts (103.2mV).

Since the output is not filtered it is strongly recommended to use a band pass filter within the user software.

The temperature value (T_{AMB}) may vary from part to part at room temperature.



深圳市晶创和立科技有限公司

Responsivity: **min.: 6,0 kV/W** **typ.: 8,0 kV/W**

Responsivity is measured within spectral range 7 - 14 μm as per fig. 3 at 1Hz.

Match: **max.: 10 %**

Electrical balance (match) is measured with same test set up as responsivity, both elements exposed to radiation. A percent value is calculated as

$$\frac{100 \times S_m}{s}$$

S_m : signal (match)
 s : signal of left or right element.

Noise: **max.: 100 μV_{pp}** **typ.: 40 μV_{pp}**

After a 10 minute settling time, noise is monitored for the duration of 1500 sec. at a temperature of 25°C, shut from infrared energy, digital filter between 0.4 to 10Hz.

Typical Responsivity vs. Frequency

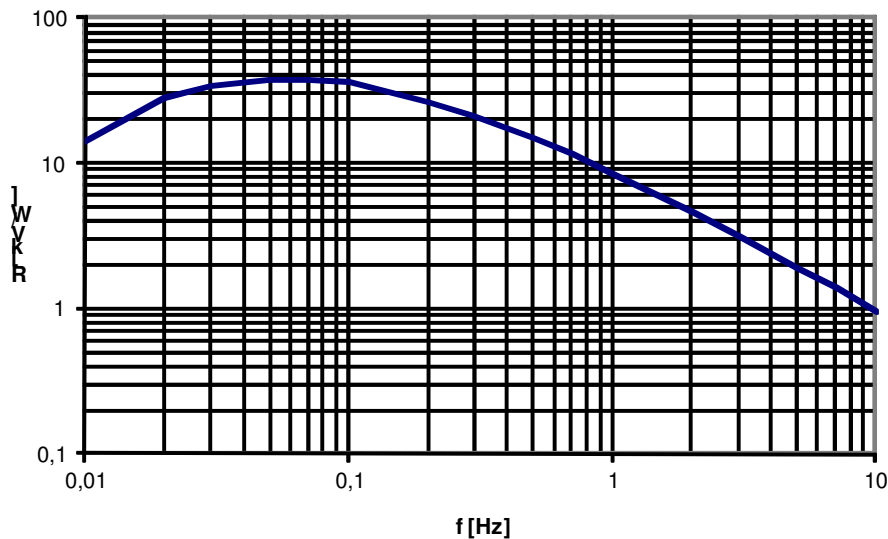

Fig. 3: Frequency response

Sample data

The samples attached to this specification have been randomly selected. Test equipment as per fig. 3 and fig.4.

Tab.2: Sample data

Sample no.	R_A [kV/W]	$R_{A'}$ [kV/W]	Match _A [kV/W]	R_B [kV/W]	$R_{B'}$ [kV/W]	Match _B [kV/W]
1						
2						
3						
4						
5						
6						
7						
8						
9						
10						

Test Set up

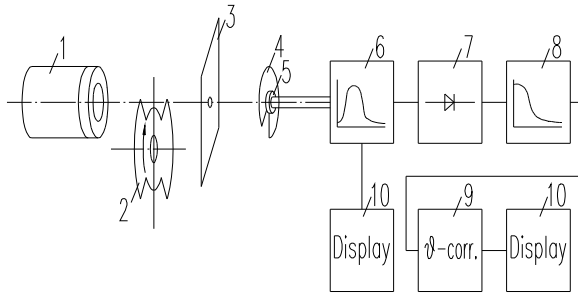

- 1: Black Body Radiator 373K = 100°C
- 2: 1 Hz Chopper
- 3: Aperture
- 4: Cover plate
- 5: Detector
- 6: Bandpass filter 1 Hz
- 7: Rectifier
- 8: Lowpass filter
- 9: Temperature compensation
- 10: Display

Fig. 4: Test Set – up

Responsivity A'/B'

Responsivity A/B

Match

Noise

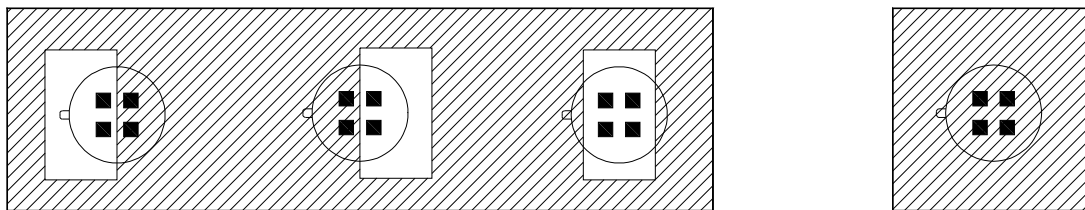

Fig. 5: Responsivity measurement

Spectral range:

The spectral range of the detector is determined by the built-in filter (window).

Substrate:

Silicon, multilayer coated

Cut – on:

$5.5 \pm 0.3 \mu\text{m}$

Transmission:

$T > 77\%$ average between $7 \mu\text{m}$ and $14 \mu\text{m}$

Blocking:

$T < 0.1\%$ for $\lambda < 5 \mu\text{m}$



Physical Configuration:

Housing: TO- 5 metal housing with infrared transparent window

Element size: 1 x 1, see also drawing: 2/71850

Connections: Refer to drawing: 2/71850

Field of View

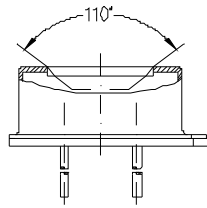

Fig. 6: Field of View

Operating temperature: -40 °C to +85 °C

The electrical parameters may vary from specified values accordance with their temperature dependence.

Storage temperature: -40 °C to +85 °C

Avoid storage under high humid environment.

Microphonic noise: max: 30 μV_{rms} /g

Excelitas IR-detectors covered herein have passed qualification test for microphonic noise in x-y-z axis, exciting frequencies from 5Hz to 2kHz.

Humidity:

The IR-detector shall not increase noise or decrease responsivity when exposed to 95% R.H. at 30 °C. Operation below dew point might affect performance.

Hermetic seal:

This IR-detector is sealed to pass a He-leakage test with maximum leak rate of 10^{-8} mbar.l.s⁻¹.

Quality:

Excelitas Technologies is a **QS 9000** certified manufacturer with established SPC and TQM. Detector out-going inspections include the parameters Responsivity, Match, Offset, Noise, Gross leak (Mil Std 883 method 1014C1). Individual data are not stored, statistical details can be disclosed on request.



深圳市晶创和立科技有限公司

Handling:

Handle the detectors as ESD sensitive devices and protect them from electrostatic discharges. Working areas should be conductive and grounded. When handling detectors, operators shall be grounded. Avoid mechanical stress on the housing and especially on the leads. Be careful when cutting or bending leads to avoid damage. Do not bend leads less than 5 mm from their base. Do not drop detectors on the floor.

Avoid touching the detector window. To clean windows, only use ethyl alcohol with a cotton swab when necessary. Do not expose detector to aggressive detergents such as Freon, trichloroethylene, etc.

Soldering conditions:

For the soldering of the detectors within PCBs, the typically applied and recommended process is wave soldering. The soldering temperature should not exceed 285° C with a maximum exposure time of 5 seconds. During the automatic wave solder process we strongly advise to restrict preheating when the detector is directly exposed to the radiation of such heaters. In this case, the detector should be protected from the heat.

Manual soldering is also possible when maintaining similar temperature profiles. Reflow soldering is not possible due to the high temperature profiles of the process.

Product Safety & RoHS:

Modern high-tech materials are applied in the production of our pyro-electric detectors. Some of these materials are sensitive to high temperature exposure or to specific forms of stress. Our parts are compliant with environmental regulations as can be reviewed on the Excelitas website. We recommend to always check your local regulations. Disposal shall only be carried out in accordance with the latest legislation and directives. In Europe, WEEE directives must be followed.

The leads of these detectors have been pre-tinned with lead free tin process and may be applied through lead-free solder processes. As such the detectors will enable the design of RoHS compliant products.

Marking:

The marking of the detector includes the principal type plus a 4 digit number that represents the Excelitas storage and specification number (3XXX) and a date code, consisting of years and week detail. The marking is on the top or side of the detector.

Performance Advice

Before taking a reading, during testing, and / or operation the unit has to become thermally stable due to its nature as a thermal detector and the high sensitivity of the device.

All data are specified at room temperature. When operating at other temperatures within the specified operating range, parameters may vary. The detectors might operate outside the quoted range but may have degraded performance.

The reproduction, transmission or use of this document or its contents is not permitted without express written authority. Offenders will be liable for damages. All rights, including rights created by patent grant or registration of a utility model or design are reserved.

Weitergabe sowie Vervielfältigung dieser Unterlage, Verwertung und Mitteilung ihres Inhalts nicht gestattet, soweit nicht ausdrücklich zugestanden. Zuwiderhandlungen verpflichten zu Schadensersatz. Alle Rechte vorbehalten, insbesondere für den Fall der Patenterteilung oder GM-Eintragung.

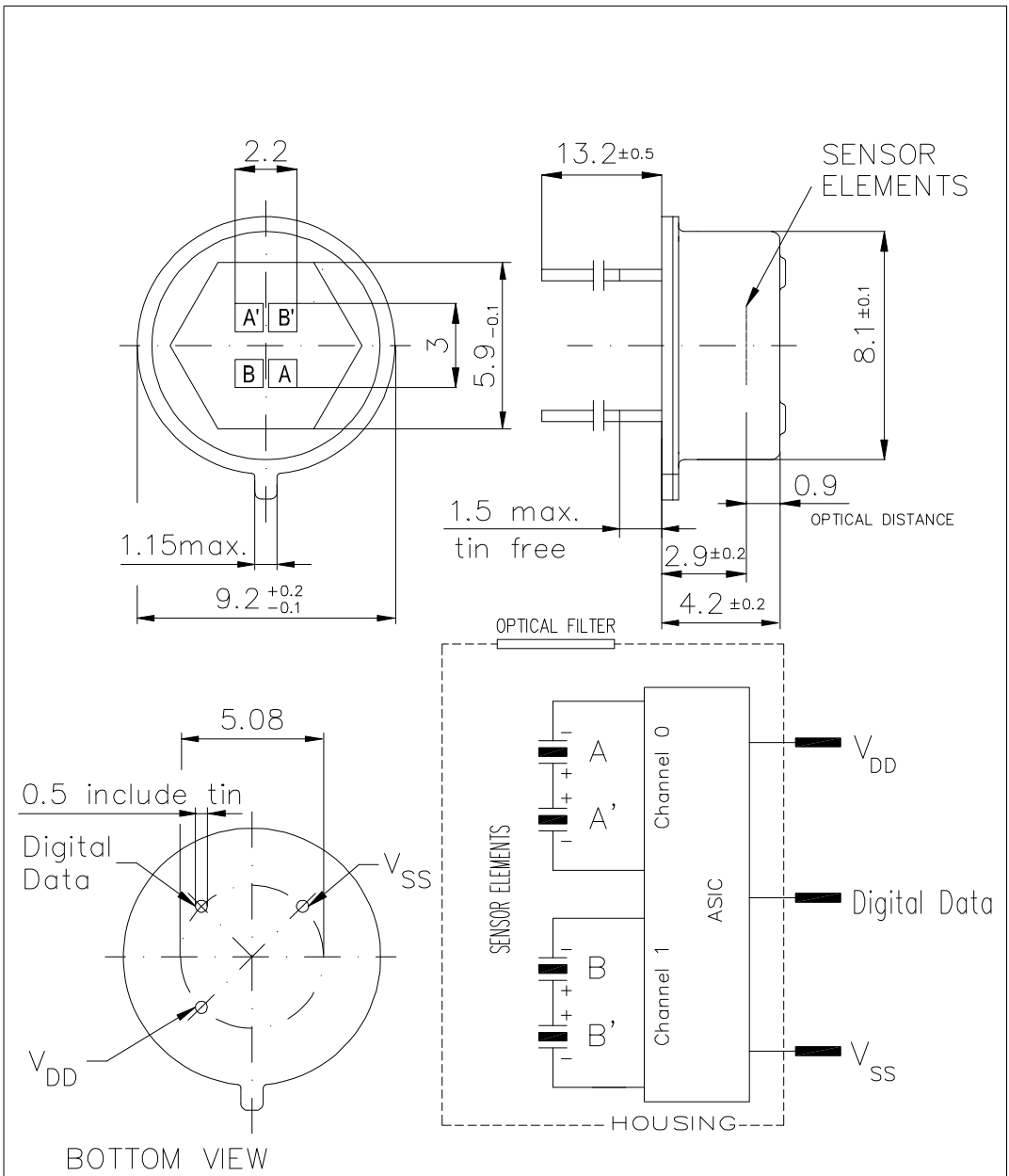

Allgemeintoleranzen GENERAL TOLERANCES				Werkstückkanten/EDGES OF WORKING-PARTS ACC. DIN 6784		Form- u. Lagetoleranzen GEOMETRICAL TOLERANCES	
			Datum DATE	Name NAME	Werkstoff MATERIAL		
	Gez. DRAWN BY	09.07.09		Tkocz			
	Gepr. CHECKED BY	28.01.2011					
	Maßstab SCALE	Benennung/TITLE				Zeichnung Nr./DRAWING NO.	
		5:1				2/71850	
		ELEMENTORIENTATION AND CONNECTIONS PYQ 5868				Ersatz für/REPLACEMENT FOR	
						Ersetzt durch/REPLACED BY	

A4.dwg