



晶创和立的HL304HP是一款高灵敏度的光敏传感器，插件式外型封装，是传统 CDS 光敏电阻的理想替代产品。

Jingchuangheli is a high sensitivity optical sensor, in DIP package. It's the ideal substitute for traditional CDS photosensitive resistor.

特性 Features

- 1) 感光峰值波长 850nm Photosensitive peak wavelength $\lambda_p=850\text{nm}$
- 2) 高可靠性 High reliability
- 3) 低功耗 Low Power Consumption
- 4) 符合 RoHS RoHS compliant

应用 Applications

- 1) 替代传统 CDS 光敏电阻 Replacement of conventional CDS photosensitive resistors
- 2) 适用于各类光控照明产品：如小夜灯等 Suitable for all kinds of light products: such as night lamp etc.

- 3) 自动调节背景光：如 LCD、手机、照像机、电脑摄像头等 Products which need to adjust background light automatically, LCD, mobile phone, camera, computer camera etc.
- 4) 控制各类光控影控玩具 Control all kinds of light and shadow controlled toys
- 5) 各类光控红外检测测试设备等 All kinds of infrared light detection and testing equipment

量身订制 Customization

- 1) 品种齐全,生产周期短,小批量库存备货 Complete varieties, short production cycle, small batch inventory
- 2) 可按要求提供不同外型,角度,方便安装于产品的任何位置 Customize different shapes and angles
- 3) 可按需求提供最佳的规格,以便让产品效果更好,更具市场竞争力 Customize most suitable specifications to make the product be more competitive

光电特性 Elector-Optical Characteristics (Ta=25°C)

参数 Parameter	Symbol	Test Condition	Min.	Typ.	Max.	Unit
感光峰值波长 Photosensitive peak wavelength	λ_p	\	--	850	--	nm
感光波宽范围 Sensitivity wave width	λ	\	400	--	1100	nm
集电极—发射极电压 Collector-emitter Breakdown Voltage	B_{vce0}	$I_C=100\mu A$ $E_e=0\text{mW}/\text{cm}^2$	30	--	--	V
发射极—集电极电压 Emitter-Collector Breakdown Voltage	B_{veco}	$I_E=10\mu A$ $E_e=0\text{mW}/\text{cm}^2$	6	--	--	V
集电极发射极饱和电压 Collector-Emitter saturation voltage	$V_{ce(sat)}$	$I_C=2\text{mA}$ $E_e=1\text{mW}/\text{cm}^2$	--	--	0.4	V
光电流 Photo-current	IL(1)	$V_{CE}=5V$ $E_v=10\text{Lux}$	3	5	7	μA
	IL(2)	$V_{CE}=5V$ $E_v=30\text{Lux}$	9	15	21	μA
	IL(3)	$V_{CE}=5V$ $E_v=100\text{Lux}$	30	50	70	μA
暗电流 dark current	I_{ceo}	$V_{CE}=5V$ $E_v=0\text{Lux}$	--	--	0.1	μA
开启时间 Rise time	t_r	$V_{CE}=5V$ $I_C=1\text{mA}$ $R_L=1000\Omega$	15			us
关闭时间 Fall time	t_f		15			



额定参数 Absolute Maximum Ratings (Ta=25°C)

电气特性	Electrical characteristics	Symbol	Rated Value	Unit
集电极—发射极电压	Collector-emitter Voltage	V _{CEO}	30	V
发射极—集电极电压	Emitter-Collector Voltage	V _{ECO}	6	V
功耗	Power Dissipation	PC	70	mW
工作温度	Operating Temperature	T _{opr}	-30--+85	°C
储存温度	Storage Temperature	T _{stg}	-40--+100	°C

可靠性试验 Reliability Test

测试项目	Test Parameter	参考标准	Reference Criterion	测试条件	Test Condition	时间	Time	样品数	Quantity	Ac/Re
耐焊接热	Resistance to Solder Heat	JESD22-B106		260°C±5°C		10 sec		22PCS		0/1
冷热循环	temperature cycle	JESD22-A104		+100°C(15min) 5min -10°C(15min)		50 cycles		22PCS		0/1
冷热冲击	Thermal Shock	JESD22-A104		+105°C(30min) 5min -45°C(30min)		50 cycles		22PCS		0/1
高温贮存	High Temperature storage	JESD22-A103		+100°C		1000H		22PCS		0/1
低温贮存	Low Temperature storage	JESD22-A119		-40°C		1000H		22PCS		0/1
寿命测试	Life Test	JESD22-A108		V _{CE} =5V		1000H		22PCS		0/1
高温高湿	High Temperature and High Humidity Test	JESD22-A101		85°C & 85% R.H		168H		22PCS		0/1

光电特性曲线 Typical photoelectric characteristics curves

感光特性曲线 Photographic property Curve

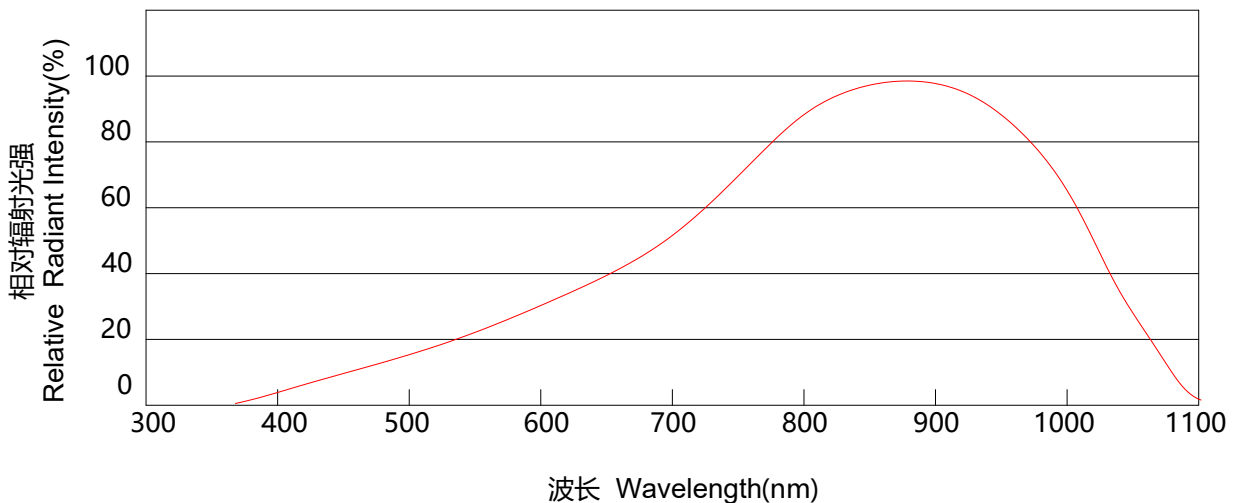

应用电路 Application circuit

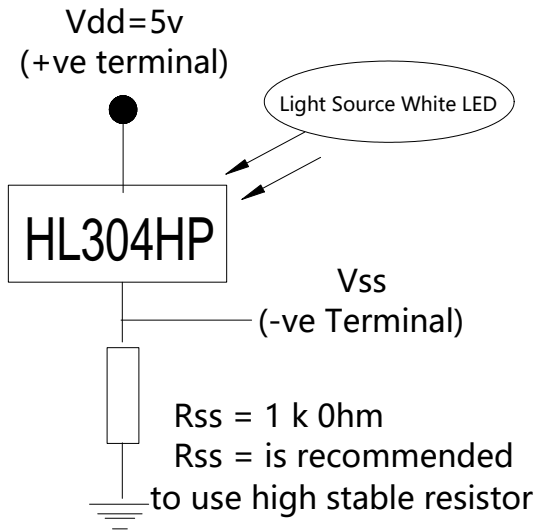

LED通用驱动电路

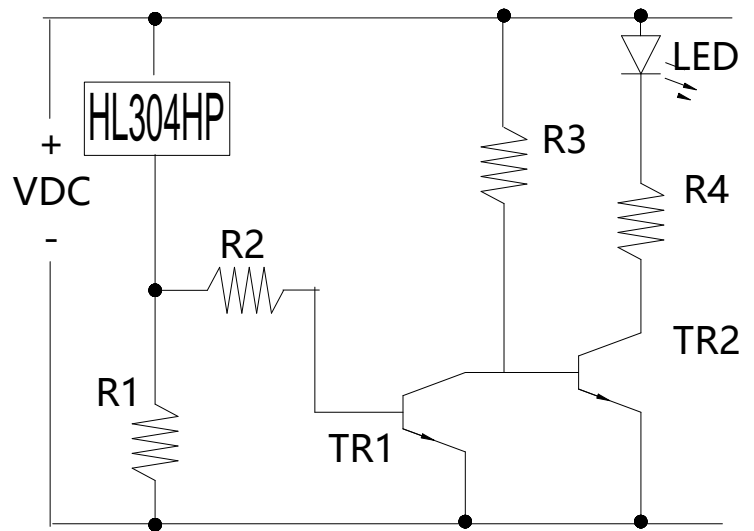

当光照低于光照阈值时，TR1三极管关闭，TR2三极管导通，LED导通。当环境光照大于光照阈值时，TR1降低的电流并使TR2截止，LED不导通。

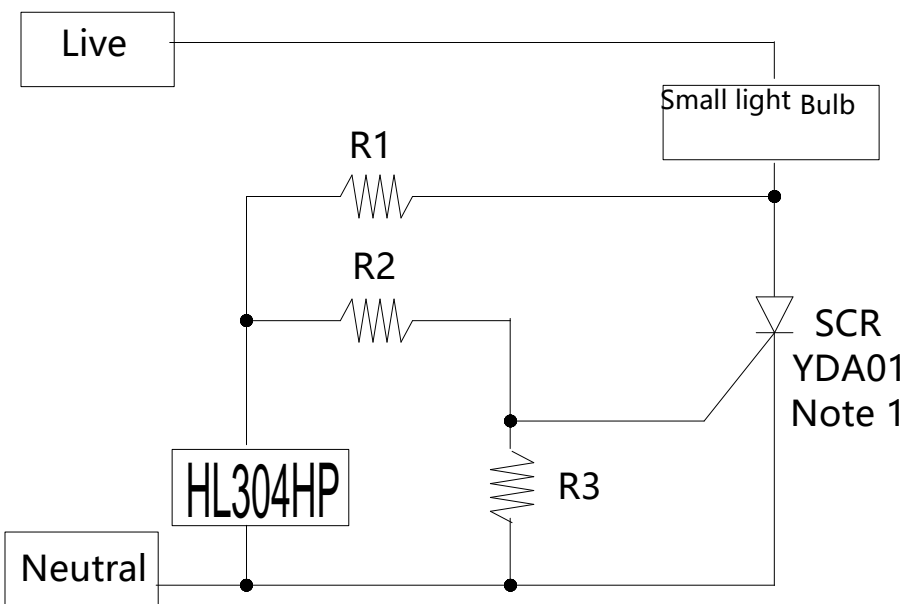

该电路需要一个敏感的可控硅。灯泡的电流是由敏感的可控硅开关空置。当光量超过阈值时，该VC与VE引脚之间的电流转移了可控硅的栅极电流。光切换阈值可通过选择R2和R3不同的值进行调整。

包装规格

Packing Specification

■ 标签规格

Label specification

深圳市晶创和立科技有限公司	
产品名称	
规格型号	
订单编号	
物料编号	
产品数量	
发货时间	

■ 静电袋包装

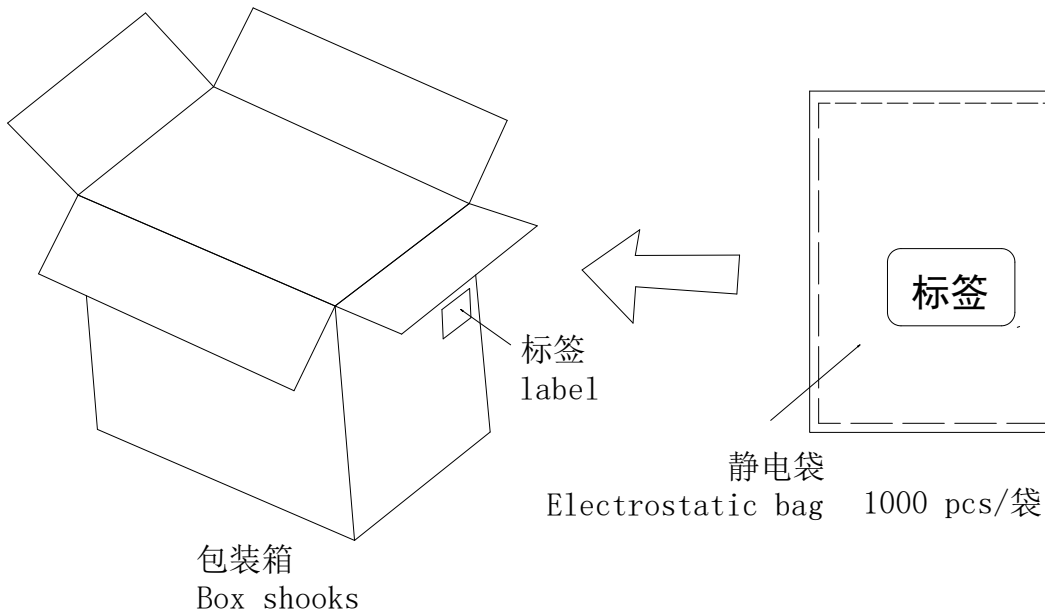

产品外型尺寸

Package outline dimensions

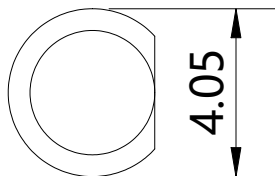

备注：所有尺寸单位均为 mm，
如无特殊说明误差范围为±0.15mm

Note : All dimensions in mm,
tolerance is ±0.15mm unless
otherwise noted

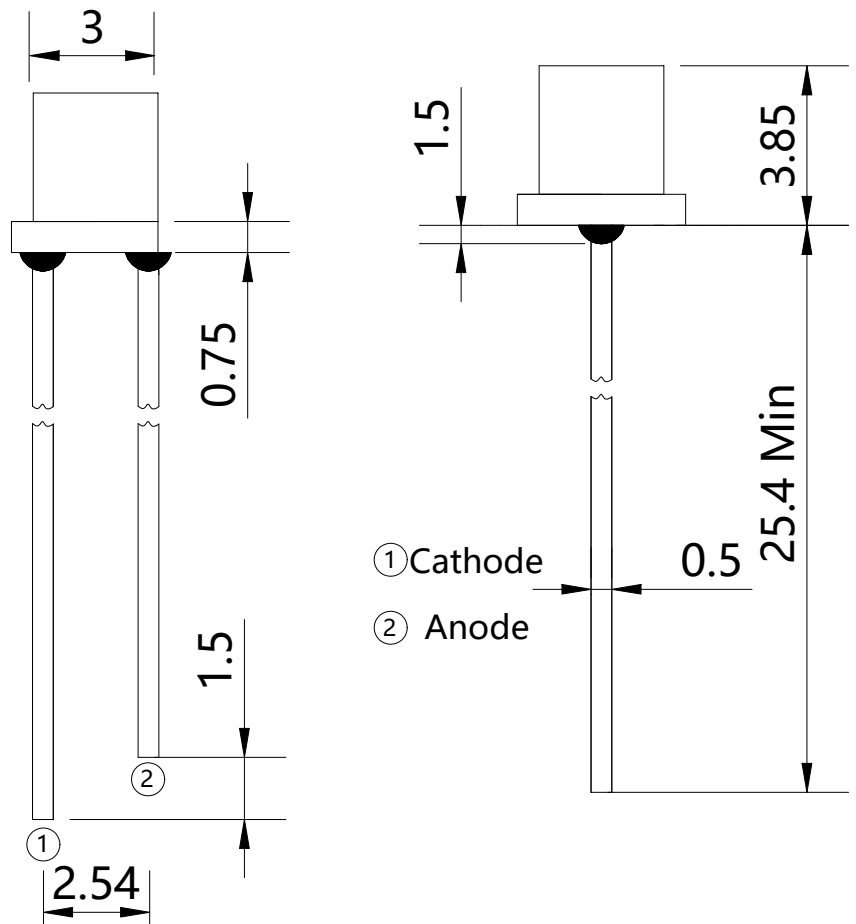



焊接 Soldering

焊接过程中的不慎操作将会引起产品的损坏,请务必注意。焊接过程中应避免对产品支架或封装部分施加压力。焊接时,请保证焊接位置与封装树脂底部有一定的距离,该距离因不同的焊接方法而有所不同,请参照以下推荐焊接条件。
Damages may be caused during soldering, please be careful. Please note that don't put stress on product bracket or package part when soldering. And make sure keep some distance from soldering joint to the bottom of epoxy package when soldering. The distance is determined by different soldering techniques, it's recommended to take following soldering conditions as reference.

推荐焊接条件 Recommended Soldering Conditions

焊接模式 Mode		固定形式 Fixed form
手工焊接 Manually Soldering	烙铁温度 Soldering Iron Temperature	最高温度 300°C(功率最大 30 瓦) Max 300°C (power:30w Max)
	焊接时间 Soldering Time	时间不超过 3 秒 3 sec Max.
	焊接位置 Soldering Position	大于 3mm (从焊点到胶体) 3mm Min.(Form soldering joint to colloid)
波峰焊接 Wave Soldering	预热 Preheat	最高温度 100°C 不超过 60 秒 100°C Max.60 sec.Max.
	温度 Temperature	最高 260°C 260°C Max.
	焊接时间 Soldering Time	不超过 5 秒 5 sec Max.
锡炉焊接 Solder pot Soldering	预热 Preheat	最高温度 100°C 不超过 60 秒 100°C Max.60 sec.Max.
	浸焊温度 Preheat Temperature	最高 260°C 260°C Max.
	浸焊时间 Soldering Time	不超过 5 秒 5 sec Max.
	焊接位置 Soldering Position	大于 2mm (从焊点到胶体) 2mm Min.(Form soldering joint to colloid)

- 本产品不适合做回流焊接。It's unsuitable for reflow soldering.
- 手工焊接只可焊接一次。Manually soldering should be done once only.
- 器件外部温度在 40°C 以下时, 才可以对其进行处理。避免高温时操作对 ALS 造成损伤。Please solder the ALS under 40 degree to avoid high temperature damage the device
- 在焊接温度回到正常以前, 必须避免使 ALS 受到任何震动或外力 After soldering the ALS ,please keep it out of any shake or outer force before it come to normal temperature
- 在焊接后推荐使用酒精进行清洗, 在温度不高于 30°C 的条件下持续 1 分钟, 不高于 50°C 的条件下持续 30 秒。使用其他类似溶剂清洗前, 请先确认使用的溶剂不会对 ALS 的封装和环氧树脂部分造成损伤。

It is recommended that to use alcohol clean ALS after soldering. Cleaning should be done under 30°C for 1 minute or 50°C for 30 seconds. When using other solvents, please confirm whether the solvents would dissolve the package or resin beforehand

注意：此一般指导原则并不适用于所有 PCB 设计和焊接设备的配置。具体工艺受到诸多因素的影响, 请根据特定的 PCB 设计和焊接设备来确定焊接方案。

Note : This general guideline may not suitable for all PCB designs or all soldering equipment configurations .The technique in practice is influenced by many factors. Please confirm soldering method by the PCB designs and configurations.